

次のそれぞれの図形のかげの部分の面積を求めなさい。

1.

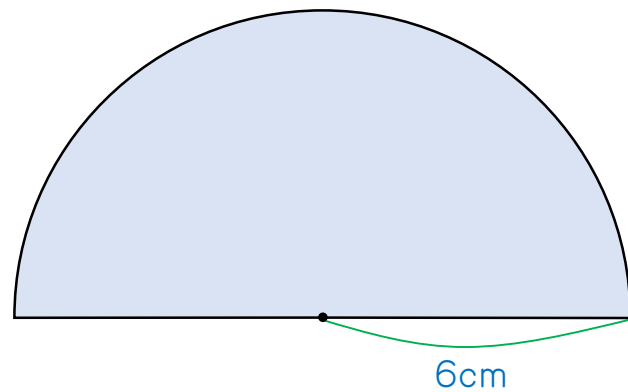

2.

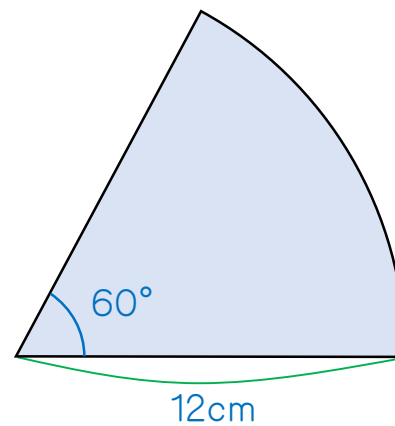

3.

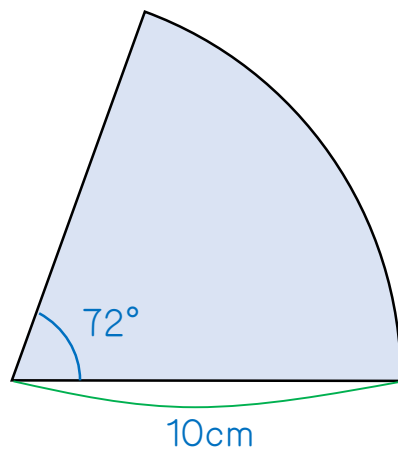

4.

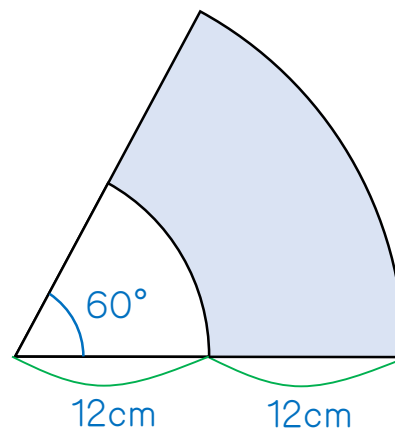

次のそれぞれの図形のかげの部分の面積を求めなさい。

5.

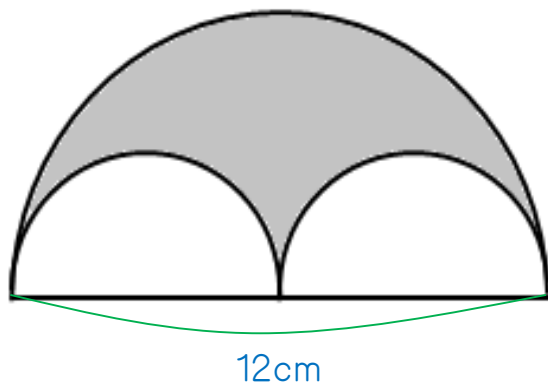

6.

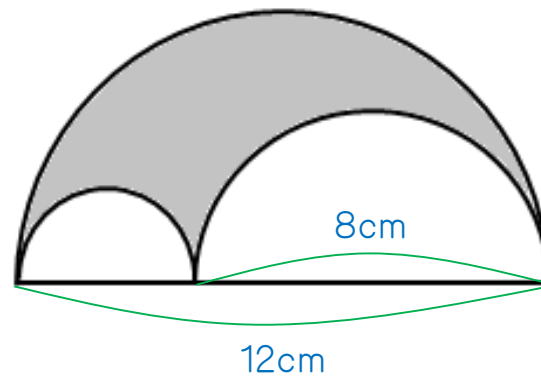

7.

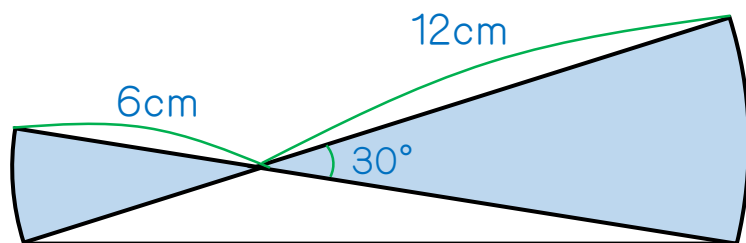

1.  $56.52\text{cm}^2$

2.  $75.36\text{cm}^2$

3.  $62.8\text{cm}^2$

4.  $226.08\text{cm}^2$

5.  $28.26\text{cm}^2$

6.  $25.12\text{cm}^2$

7.  $47.1\text{cm}^2$