

次のそれぞれの図形のかげの部分の面積を求めなさい。

1.

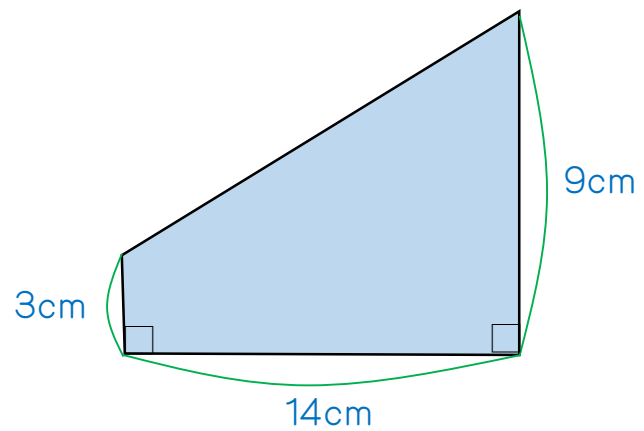

2.

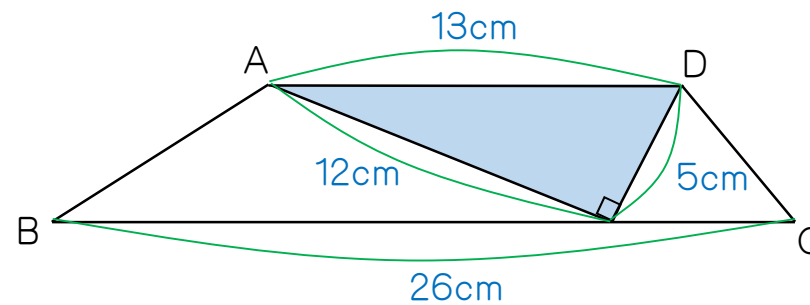

3.

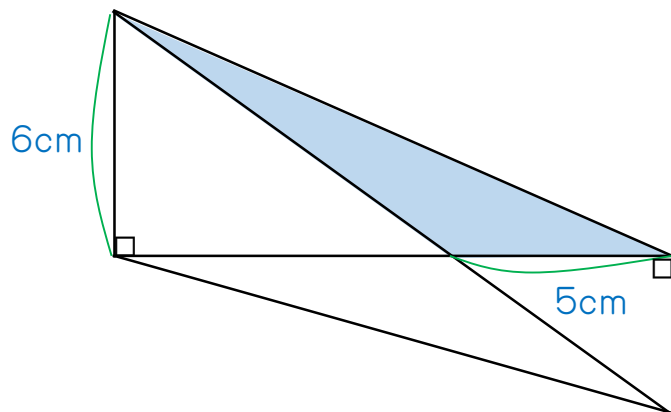

4.

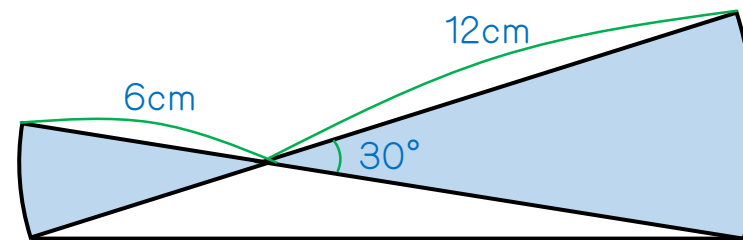

5.

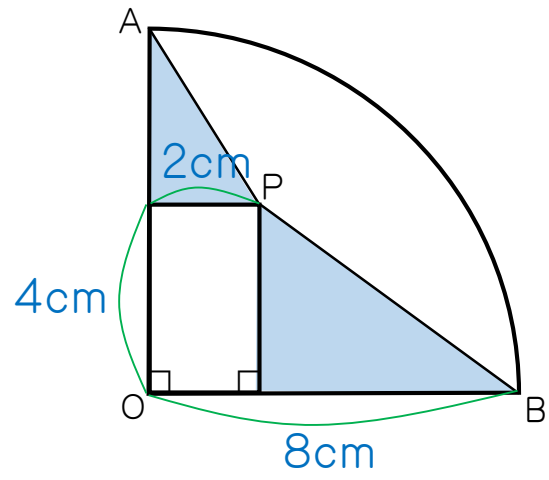

6.

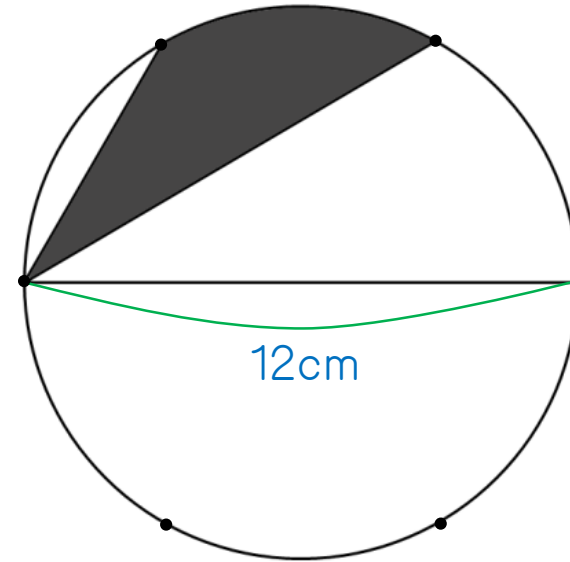

(6等分円)

1. 84cm^2

2. 30cm^2

3. 15cm^2

4. 47.1cm^2

5. 16cm^2

6. 18.84cm^2