

次のそれぞれの図形のかげの部分の面積を求めなさい。

1.

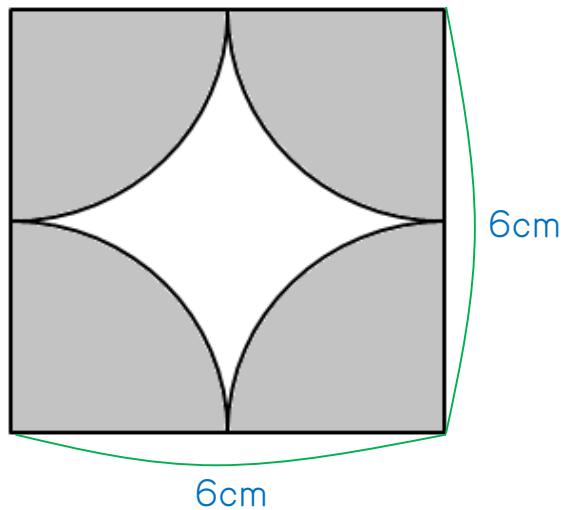

3.

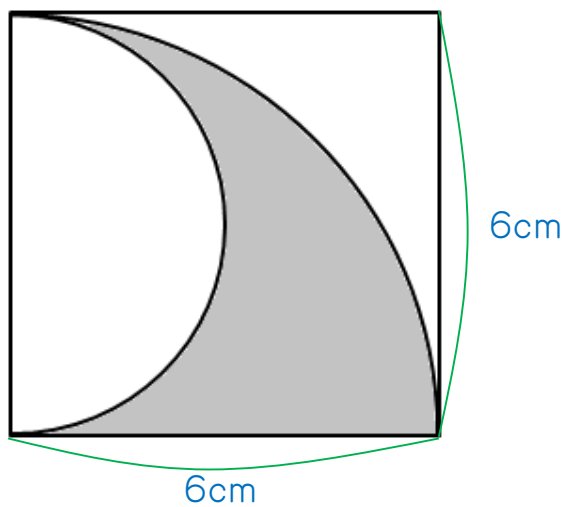

2.

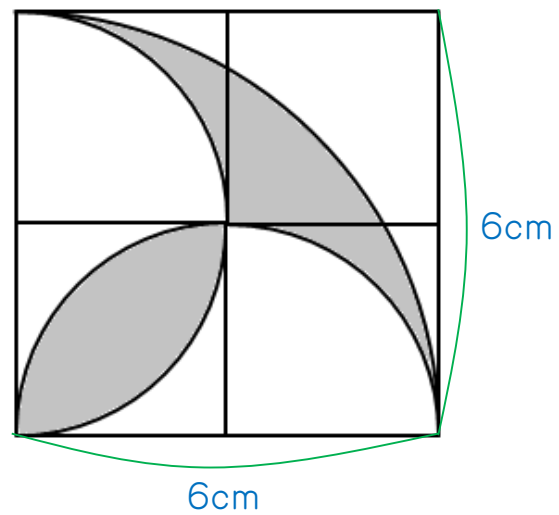

4.

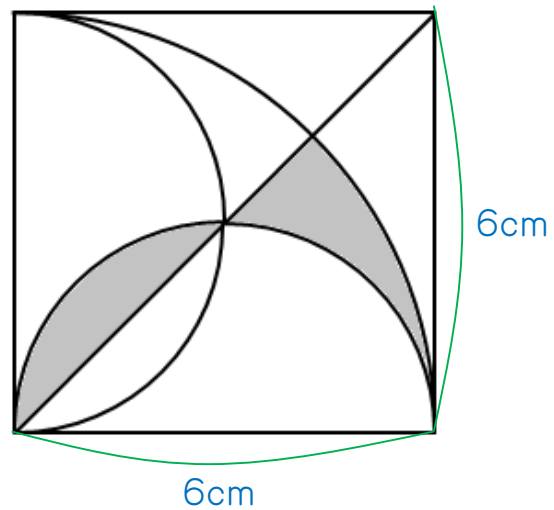

5.

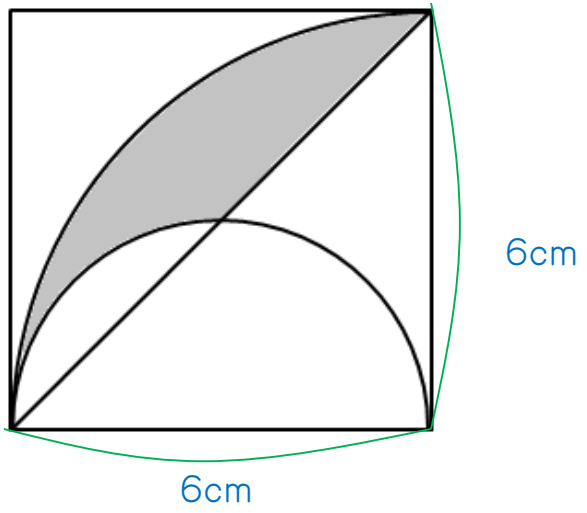

6.

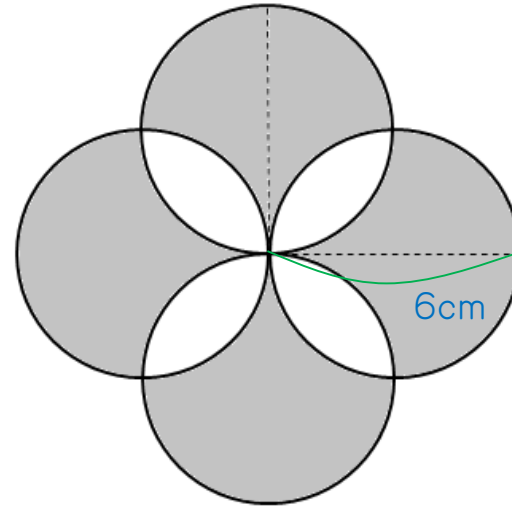

7.

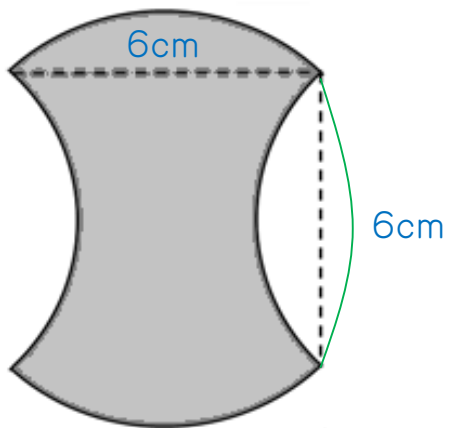

8.

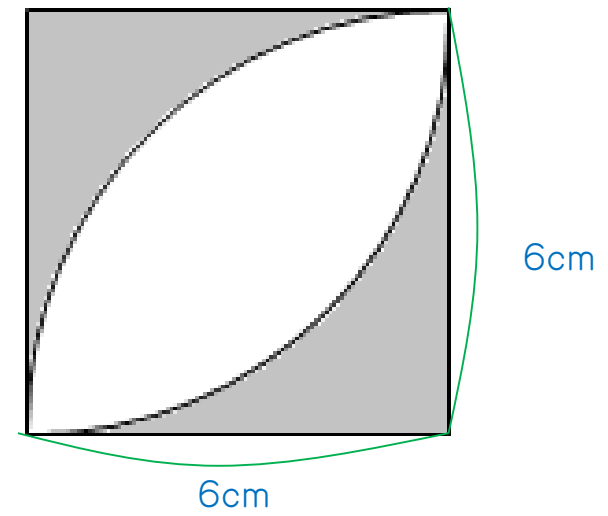

9.

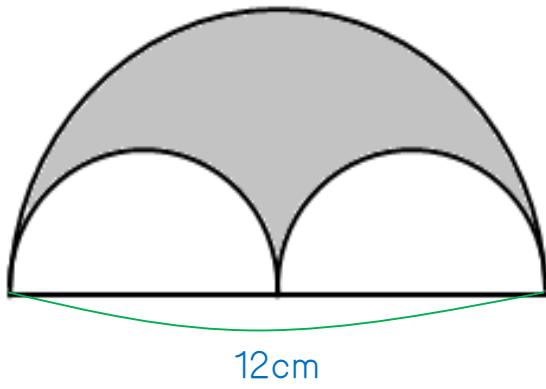

10.

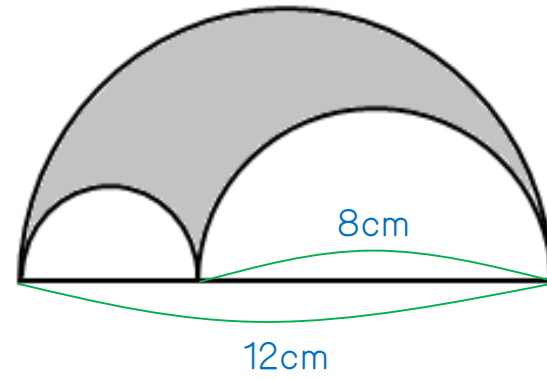

1. 28.26cm^2

2. 10.26cm^2

3. 14.13cm^2

4. 5.13cm^2

5. 7.695cm^2

6. 72cm^2

7. 36cm^2

8. 15.48cm^2

9. 28.26cm^2

10. 25.12cm^2