

次のそれぞれの図形の面積を求めなさい。

1.

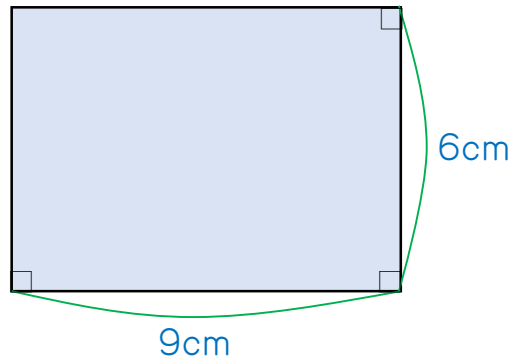

2.

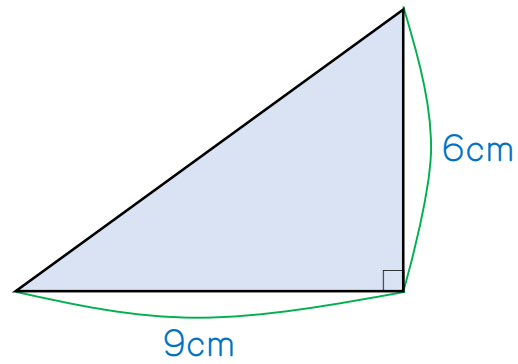

3.

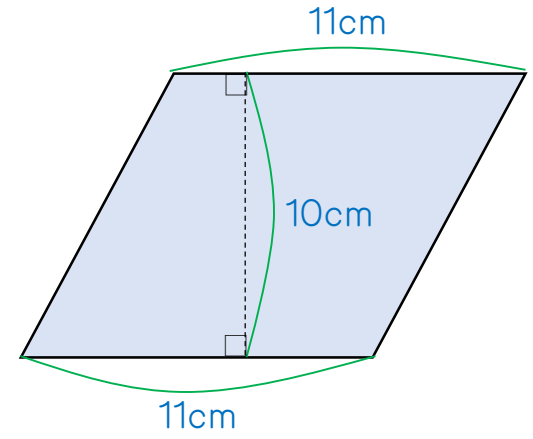

4.

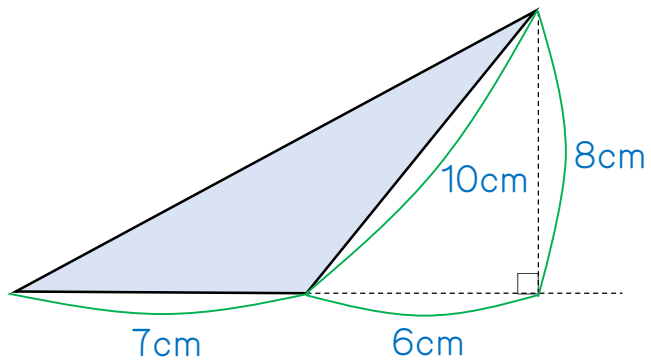

5.

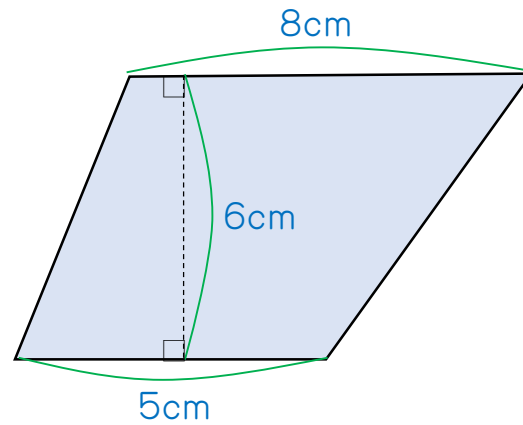

6.

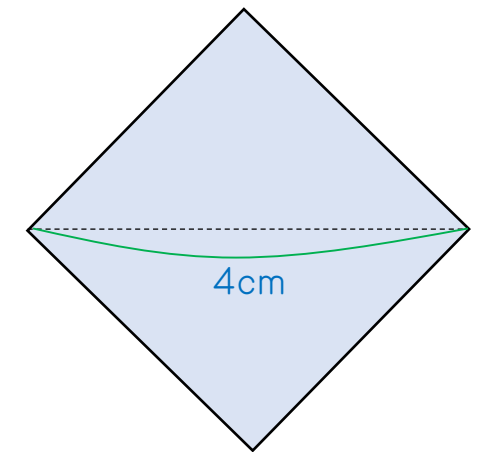

←正方形

次のそれぞれの図形の面積を求めなさい。

7.

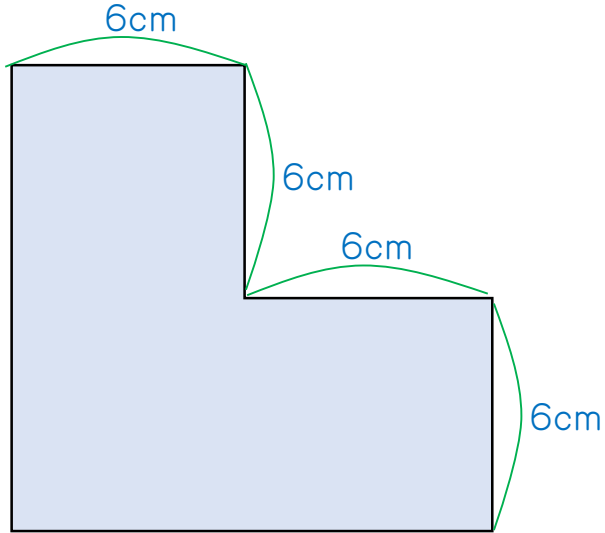

8.

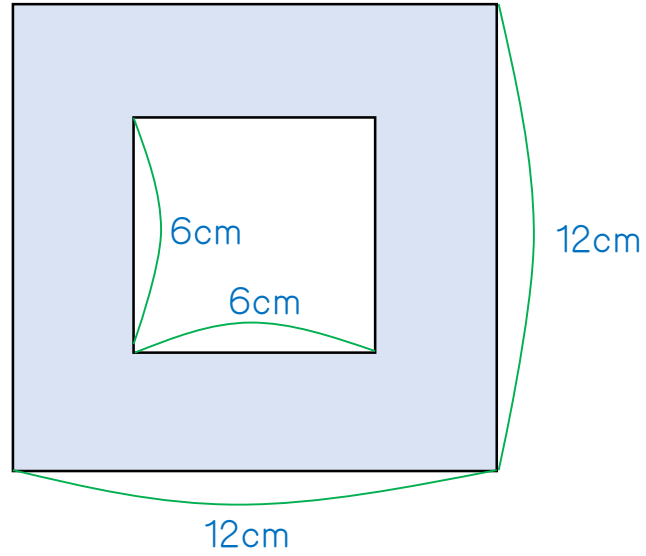

9.

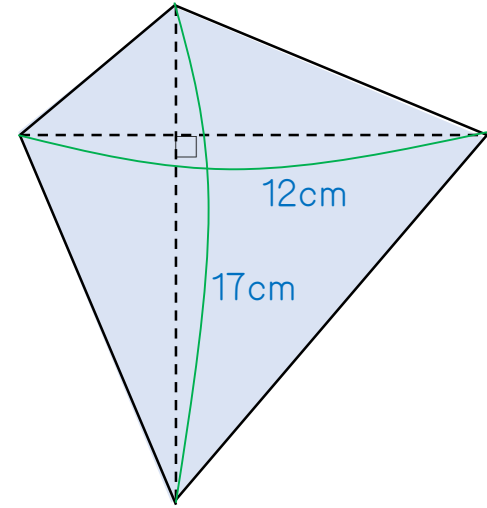

10.

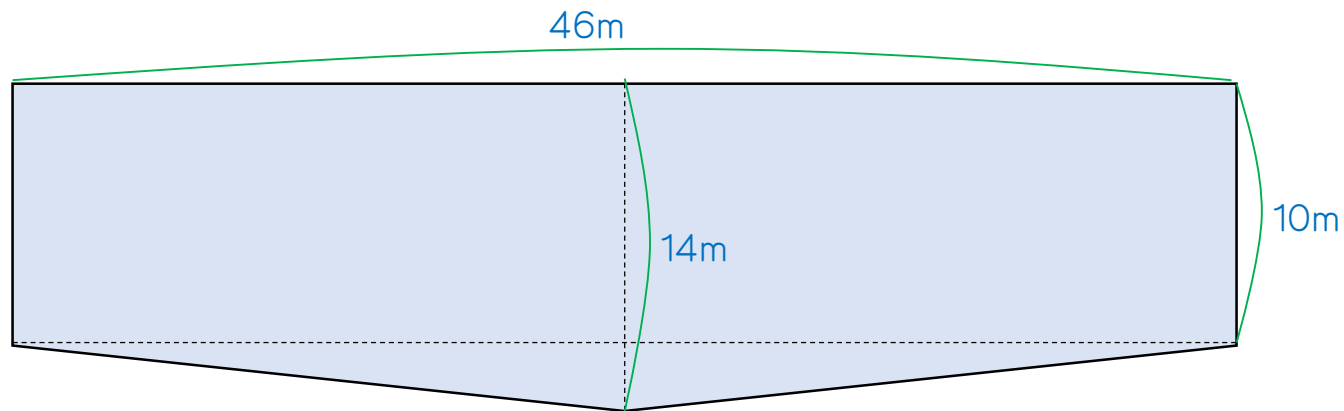

1. 54cm^2

2. 27cm^2

3. 110cm^2

4. 28cm^2

5. 39cm^2

6. 8cm^2

7. 108cm^2

8. 108cm^2

9. 102cm^2

10. 552m^2