

次のそれぞれの体積を求めなさい。

1.

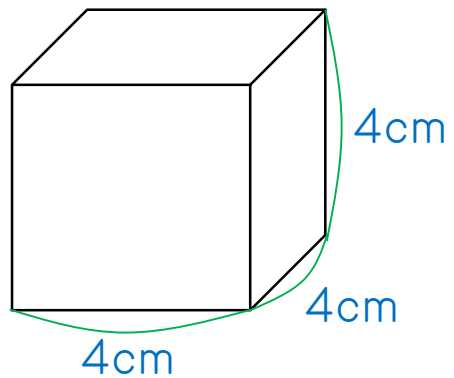

2.

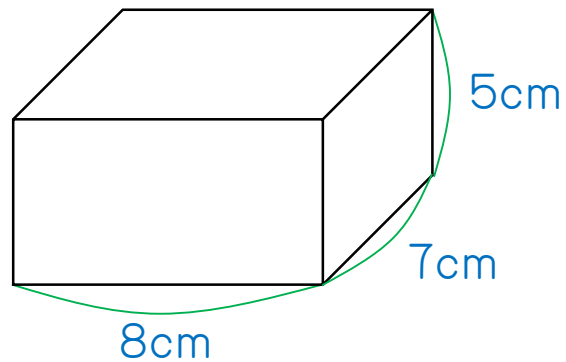

3.

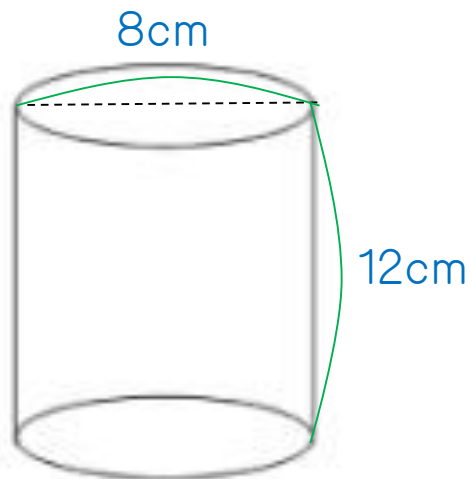

4. (円周率は、3.14を使いなさい)

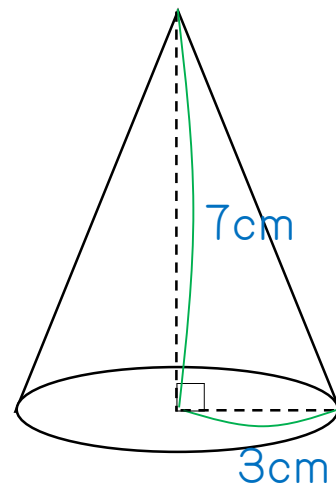

次のそれぞれの**表面積**を求めなさい。(ちなみに表面積とは、空気に触れている部分のすべての面積のことを言う)

5.

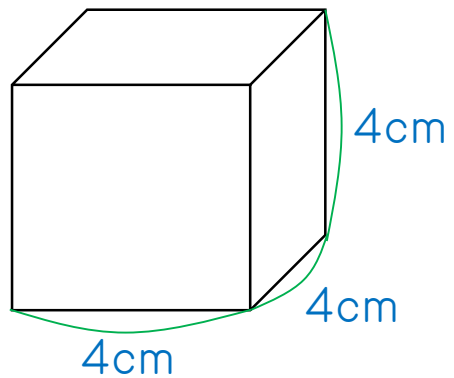

6.

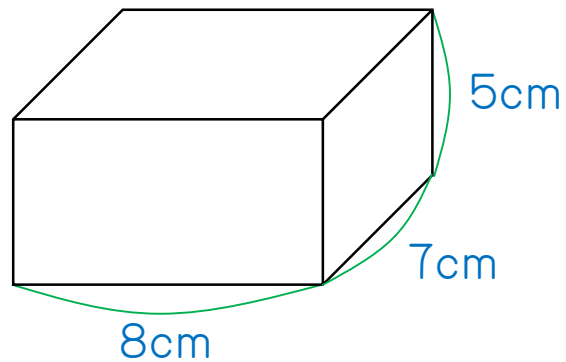

7.

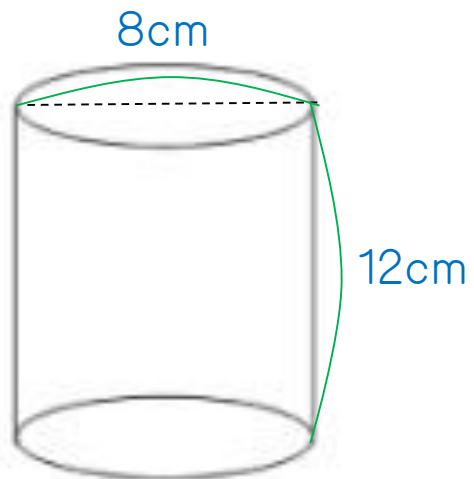

8. (円周率は、3.14をいなさい)

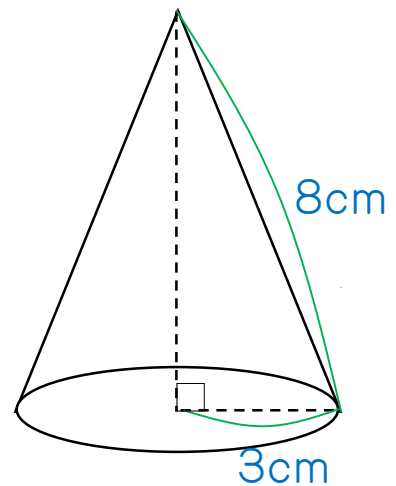

1.  $64\text{cm}^3$

2.  $280\text{cm}^3$

3.  $602.88\text{cm}^3$

4.  $32.97\text{cm}^3$

5.  $96\text{cm}^2$

6.  $262\text{cm}^2$

7.  $401.92\text{cm}^2$

8.  $103.62\text{cm}^2$